

For management and speed control of EC fans
For management and water volume control of heat exchangers with the
HydroPad/hydroBLU system

guntner.com/uk

Contents

1	General notes.....	5
1.1	Safety information.....	5
1.2	Intended use.....	5
1.3	Start-up notes.....	6
1.4	Functional description of pad wetting.....	6
1.5	Functional description of motor management.....	7
1.6	Scope of performance.....	7
1.7	Classification.....	9
1.8	Transport and storage, copyright notes.....	10
1.9	Warranty and liability.....	10
1.10	Manufacturer and shipping address.....	10
1.11	EMC-compliant installation.....	11
2	Brief guide to quick commissioning.....	12
3	Commissioning aicore fusion.....	14
3.1	Start-up menu.....	15
3.1.1	General commissioning procedure.....	16
3.1.2	Detailed start-up procedure with EC fans.....	18
3.1.3	Detailed start-up procedure with motor management.....	19
4	Structure of the aicore fusion.....	24
4.1	Installing the aicore fusion.....	24
4.1.1	Installing the controller, ventilation.....	24
4.2	Connecting the aicore fusion.....	24
4.2.1	Position of the connections on the aicore fusion.....	25
4.2.2	Controller mains connection.....	26
5	Technical data.....	27
5.1	Dimensional drawing of the aicore fusion.....	27
6	Electrical properties.....	28
7	Annex.....	31
7.1	Default I/O configuration.....	31

Supplementary documents to this document

About aicore hydroBLU:

The description of hydro management on the aicore fusion, as well as its settings, can be found in the manual "aicore™ hydroBLU".

About aicore air:

The description of motor management on the aicore fusion, as well as its settings, can be found in the manual "aicore™ air".

Version history

This manual describes all the features of the aicore fusion controller.

Some of the features described in this manual depend on the software version of the aicore fusion controller.

The table below shows the new features depending on the software version of the aicore fusion controller.

Operating manual Version	Amendments/supplements	Associated software version(s) of the aicore fusion
1.0.0	First approved version of the operating manual for GSCnext	1.10.0
1.0.1	Change of names (e.g. "GSCnext" to "aicore fusion")	1.14.0

1 General notes

1.1 Safety information

In order to prevent serious physical injuries or major material damage, work on/with the units may only be performed by authorised persons with the appropriate training and qualifications who are familiar with the set-up, installation, commissioning and operation of controllers. These persons must read the operating instructions carefully before installing and commissioning the units. In addition to the instructions and national accident prevention regulations, all recognised technical rules (safety and professional work under UVV, VBG, VDE etc.) must be followed.

Repairs to the unit may only be made by the manufacturer or a repair centre authorised by the manufacturer.

UNAUTHORISED AND IMPROPER INTERVENTIONS WILL INVALIDATE THE WARRANTY!

While the controller is open, hazardous electrical voltages are exposed; if the unit is open its protection class is IP00! The applicable national accident prevention regulations must be followed when working on controllers under voltage.

1.2 Intended use

Ensure that fuses are always replaced by fuses with the specified rating. Note that fuses should never be repaired or bridged. Only a double-pole circuit tester may be used to check that the unit is free of voltage. The unit is intended only for the purposes agreed in the order confirmation. Any other application or use for any additional purpose, is not a proper intended use. The manufacturer accepts no liability for any injury or damage arising from unintended use. Use according to the intended purpose is also contingent on compliance with the installation, operating and maintenance procedures described in these instructions. The technical data and the details of the connection assignments can be found on the name plate and in the instructions, and must be complied with.

Electronic equipment is not fundamentally failsafe! The user must therefore ensure that the system reverts to a safe condition in the event of failure of the unit. The manufacturer accepts no responsibility for any damage to life and limb or to material goods and assets in the event of failure to comply with this provision and in the event of improper use.

The electrical installation must be performed in accordance with the relevant regulations (e.g. wire cross-sections, fuses, earth conductor connections etc.). Additional information is included in the documentation. If the controller is used in a particular area of application, the required standards and regulations must be complied with.

1.3 Start-up notes

Prior to start-up the control device, check whether any residual moisture (condensation) has formed in the housing. If so, the unit must be dried out. The same applies if the sachet of silica gel (desiccant) has discoloured as this indicates that the sachet of silica gel is no longer providing any protection against moisture. If there are large volumes of condensation (droplets on the interior walls and components), they must be removed manually. Once the unit has been commissioned for the first time, the power supply and the internal control voltage must no longer be switched off for a long period. If this should nevertheless be necessary for operational reasons, suitable moisture protection must be provided.

1.4 Functional description of pad wetting

The humidification system is used for increasing the capacity of the heat exchanger at peak load times with high ambient temperatures and for more efficient heat dissipation with moderate ambient temperatures. The adiabatic evaporation of the water on the HydroPads cools the air sucked in by the heat exchanger, which increases the heat exchanger's capacity.

The pad wetting function of the aicore fusion assumes the management for controlling the wetting. The required water volume is calculated on the basis of the load state, the ambient temperature and the humidity. The pad wetting sets the appropriate water volume using the control valve. The frost protection and hygiene regulations of the system are ensured by automatic draining. The water supply to the unit must be protected separately on site against frost. The aicore fusion also controls valves that are to be provided on site, i.e. are not included in the scope of delivery, and are to be installed in the frost-proof area.

This is particularly important if several units are operated in combination (master-slave operation) and supplied by a joint water supply line.

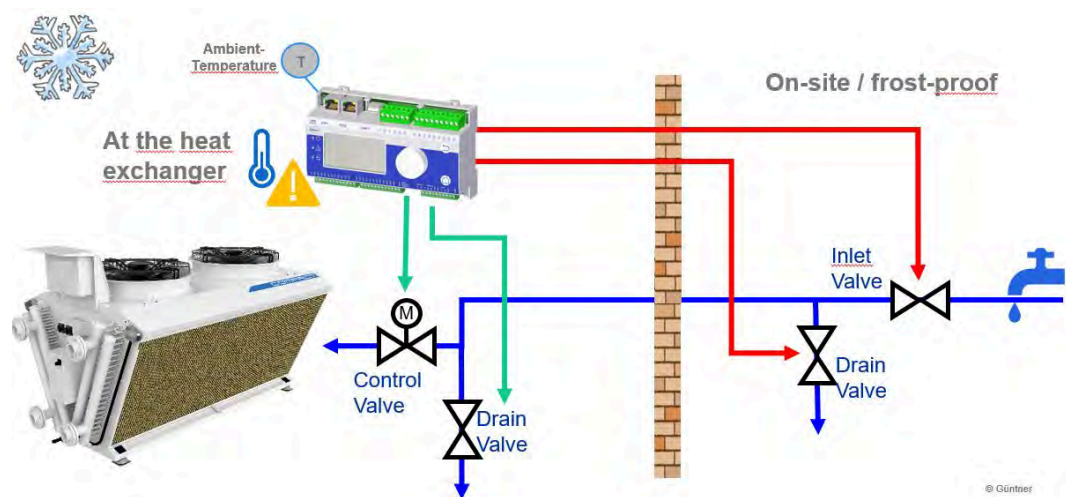

An analogue output is used to control a steady control valve that governs the amount of water on the humidification pads. The water volume is measured by the water meter of the aicore fusion.

The goal is to consume only the necessary amount of water and add it to the pads. Most of the water should evaporate before it reaches the pads.

NOTICE

You can find information about the functions and service settings, such as I/O configuration and interfaces, in the aicore hydroBLU pad wetting manual.

1.5 Functional description of motor management

The aicore fusion likewise serves to control EC fans. Alternatively, the drive type for fans can be changed via aicore fusion so that power units (e.g. with AC fans) are also controlled via an analogue signal (e.g. 0..10 V). The speed of the connected fans is adjusted depending on the regulation deviation between the actual value and the setpoint.

Depending on the model, up to 8, 16 or 24 EC fans can be controlled by the controller via separate bus segments. For controlling/regulating AC fans, separate power units (frequency converter or phase angle) can be controlled via a 0 – 10 VDC analogue signal. These fans must be set up for the condenser or dry cooler, depending on the design of the heat exchanger. These settings are necessary on initial commissioning and may need to be repeated when a fan is replaced. This commissioning process determines the performance and noise emissions.

The aicore fusion automatically detects whether commissioning is necessary when it is switched on. If this is the case, the commissioning menu is launched and the user is guided through the commissioning process.

The aicore fusion has the following inputs and outputs:

- 5 analogue inputs (AI1 to AI5), each one variably configurable
- 2 analogue outputs (AO1 to AO2)
- 5 digital inputs (DI1 to DI5)
- 5 digital relay outputs (DO1+ DO2 changeover contacts, DO3 to DO5 closers)

The input and output profiles and functions can be set via the IO configuration menu and the corresponding functions. The digital inputs are designed for positive voltages of a nominal +24V.

NOTICE

Please note that connecting the wrong voltage (e.g. 230 V) may seriously damage the controller.

NOTICE

You can find information about the functions and service settings, such as I/O configuration and interfaces, in the aicore air motor management manual.

1.6 Scope of performance

The aicore fusion's scope of performance varies depending on the system configuration and the fans connected. The following table shows key information which is evaluated to determine the scope of performance. This information can be viewed in the status menu.

Function	Options	Description
Fan drive	Modbus (EC)/Analogue	The drive type for the fans "Modbus (EC)" or "Analogue" is set during commissioning.
Inverse operation available	yes/no	If all connected fans are compatible* "yes" is shown.
Tear-off function available	yes/no	If at least one connected fan is compatible* "yes" is shown.

Properties of fans

*: EC fans controlled via Modbus and supplied later than 2012 (approximate figure, because old stocks may have been being used up) are compatible.

The following table shows the conditions for the availability of the individual aicore fusion functions. The relevant function is only available in the aicore fusion menu if the corresponding condition is met, i.e. if the connected EC fans support the function.

Function in the menu	Condition
Manual mode > Inverse operation	Inverse operation available = yes
Service > Functions > Inverse operation	Inverse operation available = yes
Service > Functions > NCC	Inverse operation available = yes
Service > Functions > Tear-off function	Tear-off function available = yes
Service > Functions > LCMM	Fan drive = Modbus (EC)
Service > Functions > Bypass	Fan drive = Modbus (EC)
Service > Functions > Analogue mode	Fan drive = Analogue

Availability of functions

Furthermore, certain diagnostic data are only available when operating EC fans controlled via Modbus. These include data for individual fans such as alarms, warnings and operating hours as well as cumulative performance data such as the total power for all fans.

1.7 Classification

The aicore fusion is available in a version for up to 24 fans in a closed IP54 housing. The power connection and control connection are located in the separate connection box (e.g. GPD).
See aicore air manual.

Classification of the IP54 version

aicore fusion/xx[.n]	
aicore fusion	Güntner Solution Controller for EC fans
xx	Number of possible connections for EC fans
.n	Hardware version: from .1: first approved hardware version

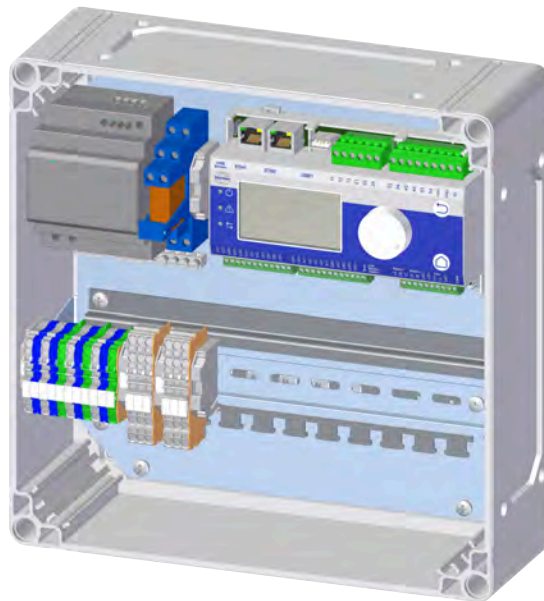

1.8 Transport and storage, copyright notes

The controllers are packaged appropriately for transport and may only be transported in their original packaging. Avoid any impacts and collisions. Unless otherwise noted on the packaging, the maximum stacking height is 4 packs. When you receive the unit, check for any damage to the packaging or the controller.

Store the unit in its original packaging and protected from the weather, and avoid extremes of heat and cold.

Products are subject to technical changes in the interests of further development. Therefore no claims may be derived from information, images and drawings; errors excepted!

All rights, including rights created by patent grant or other registration, are reserved.

These operating instructions are the copyright of

GÜNTNER GmbH & CO. KG
Fürstenfeldbruck

1.9 Warranty and liability

The current General Terms and Conditions of Sales and Delivery of Güntner AG & Co. KG apply.

See the homepage at <http://www.guentner.com>

1.10 Manufacturer and shipping address

Should you have a problem with any of our units, or any questions, suggestions or special requests, simply contact

Güntner GmbH & Co. KG
Hans-Güntner-Straße 2 - 6
82256 FÜRSTENFELDBRUCK
GERMANY

Service line:Germany:
0800 48368637
0800 GUENTNER

Service telephone worldwide:
+49 (0)8141 242-4815

Fax: +49 (0)8141 242-422
service@guentner.com
www.guentner.com

Copyright © 2024 Güntner GmbH & Co. KG

All rights, including rights of photomechanical reproduction and storage in electronic form, are reserved.

1.11 EMC-compliant installation

Controllers in the aicore air/aicore fusion series fulfil the requirements of EN 61000-6-2 as regards resistance to EMC interference and those of EN 61000-6-3 as regards emissions. They also comply with standards IEC 61000-4-4/-5/-6/-11 for grid-bound interference. In order to guarantee EM compatibility, the following points must be noted:

- The unit must be properly grounded (with at least 1.5 mm²).
- All measurement and signalling lines must be connected via shielded cables.
- If they are affected, a special cable must be used for bus wiring to the EC fans, e.g. HELUKABEL DeviceNet PUR flexible 1x2xAWG24 + 1x2xAWG22 / 81910
- The shielding of measuring, signal and bus lines must be earthed at one end only.
- Suitable shielding and routing measures must be taken to ensure that mains cables and motor cables do not cause any interference in signal and control lines.

NOTICE

If the equipment is installed in a switch cabinet, the temperature inside the switch cabinet must be heeded. Sufficient switch cabinet ventilation is provided in Güntner switch cabinets.

2 Brief guide to quick commissioning

These pages contain the main information required for quick start-up of the aicore fusion.

THIS BRIEF GUIDE IS NOT A SUBSTITUTE FOR CAREFUL STUDY OF THE OPERATING INSTRUCTIONS!

Mains connection: L1 to terminal X2 (grey)

*1) N to terminal X2 (blue)

PE to terminal XPE (green/yellow)

Fuses: *1)

To protect its semiconductors or motor, the aicore fusion contains **no** replaceable microfuses. The unit must be protected by a factory-fitted C 6A automatic circuit breaker for each phase.

Fan connection on aicore fusion

The power connection and control connection are located in the separate connection box (e.g. GPD). **See aicore air manual.**

Analogue connected power units, e.g. with AC fans, are connected to the analogue output terminals of the aicore fusion.

Communication interface: Terminal AO1 and GND (0..10 V)

*1) Only for the version in the closed IP54 casing

The fans are not powered and controlled from the aicore fusion – they are wired in an external terminal box, e.g. on the GPD (Güntner Power Distribution).

The aicore fusion has the following inputs and outputs:

- 5 analogue inputs (AI1 to AI5), each one variably configurable
- 2 analogue outputs (AO1 to AO2)
- 5 digital inputs (DI1 to DI5)
- 5 digital relay outputs (DO1+ DO2 changeover contacts, DO3 to DO5 closers)

The input and output functions can be set via the IO configuration menu. The digital inputs are designed for positive voltages of a nominal +24V.

Analogue inputs: on aicore fusion	Pressure sensor	1 (brown) on +24V
	GSW 4003	2 (green) on AIx
	GSW 4003.1	2 (blue) on AIx
	Temperature sensor	1 (white) on AIx
		2 (brown) on GND
	Standard signal (0 ... 1V)	Plus (+) on AIx
	Humidity and temperature sensor	Plus (+) on +24V
	Ambient temperature	Minus (-) on GND
	Ambient humidity	4-20mA on AIx
		4-20mA on AIx

Signalling outputs For connections for signalling outputs, see "Annex" I/O configuration.

Approval of motor management The function of the input DI1 is, by default, to release the controller. This input must be connected to +24V to ensure that the controller functions and the fans can turn!

Approval of pad wetting The function of the input DI3 is, by default, to control the pad wetting. For this, the input must be connected to +24V to ensure that the controller functions and the fans can turn!

Water meter The function of the input DI5 is, by default, to record the impulses of the water meter.

Language The default language on delivery is **English**. The display language can be changed in the Language menu option.

Time The date and time must be set using the relevant menu options.

Once the above settings have been made, the aicore fusion will normally be ready for use.

"Manual mode" can be selected to check that the aicore fusion is functioning. See aicore air manual "Manual mode"

When you deactivate manual mode after performing this test, the aicore fusion will revert to the set operating mode.

3 Commissioning aicore fusion

With the aicore fusion, the fans are controlled via a bus. These fans must be set up and checked for use with the condenser or dry cooler in accordance with the design of the heat exchanger. These settings and checks are necessary on initial start-up and may need to be repeated when a fan is replaced. This start-up process determines the performance of the heat exchanger and its noise emissions. The corresponding configurations for the heat exchanger are usually carried out ex works. However, the corresponding parameters may need to be entered again. You will find them in the attached wiring diagram or on a sticker on the heat exchanger itself.

When the aicore fusion is switched on, it automatically detects whether commissioning has taken place. If it has, the commissioning menu is skipped and normal controlled operation continues.

NOTICE

The controller will be in configuration mode until the start-up is complete. In this mode, controlled operation is not possible and the fans will be controlled with a 0 % control value. The communication interfaces and protocols are still preconfigured as follows:

- The ETH1 Ethernet interface is configured with the static IPv4 address "169.254.1.1" and the network mask "255.255.0.0".
- The RS485-1 interface is configured with the baud rate "9600 Bd" and "8N1" framing.
- The Modbus RTU and TCP protocols are activated and configured with the unit ID "1" and the TCP port "502".

If a number of controllers are commissioned in a network at the same time, conflicts can occur in the network owing to duplicate IP addresses. You can avoid this problem by ensuring that the network cable is not connected or only one controller is actively connected to the network.

Once the start-up has been completed successfully, the controller automatically switches to the set operating mode and the communication interfaces and protocols are configured in accordance with the parametrisation, see aicore air manual "Network settings" and "Field-bus settings".

3.1 Start-up menu

Switch on the power supply for the aicore fusion. At the start of the boot process, the Güntner logo will appear for 5 seconds.



As booting progresses, the firmware version of the IO controller will be shown (approx. 25 seconds).

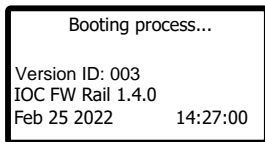

A black start screen with a cursor will then be shown for a short time (approx. 20 seconds).

Each time that the system starts, the software version of the application that is starting as well as the serial number of the controller will be shown briefly.

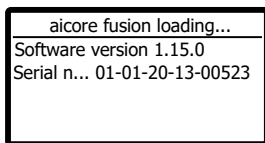

At the beginning of start-up, the language for start-up can be selected. This language setting is not permanent – it is only for start-up. After start-up, the default language for the menu is always English. The language can then be selected on a permanent basis in the Language menu.

The progress bar at the top right of the display shows your progress during start-up.



Use the rotary selection knob as well as the "Back and "Home buttons to navigate in the menu.

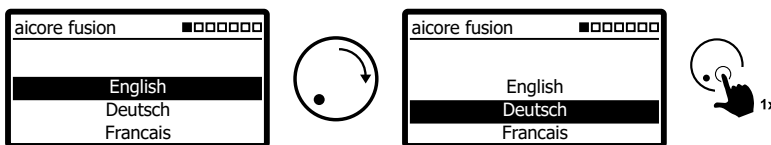

A note regarding start-up will then be shown.

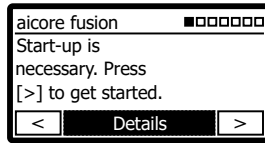

During standard commissioning, a heat exchanger can be parametrised with up to two control loops. During start-up, the analogue and digital inputs and outputs are automatically configured and assigned standard functions. An overview of the I/O configuration after start-up is available in the "Annex" .

An extended start-up with up to five control cycles can be carried out after the standard start-up via the service menu.

Please follow the instructions in the display. To initiate start-up, scroll to the right [>].

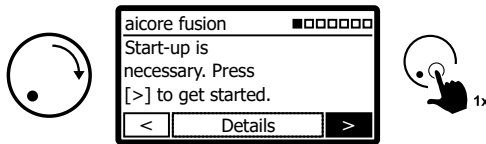

3.1.1 General commissioning procedure

The following is a systematic list of the commissioning steps:

Section	Parameter	Description
aicore fusion	Language	Selection of the language for commissioning.
Introduction	-	Note that a new commissioning is required
Date and time	Date	Setting the system date
	Time	Setting the system time
Units system	Units system	The units system used to show values in the display is shown
Pad wetting	Pad wetting	The pad wetting option can be activated here.
	Altitude above sea level	The set-up height geodata must be entered for the water volume calculation.
	Air volume flow	The set-up the air volume flow must be entered for the water volume calculation.
	Maximum flow	The maximum flow must be set so that the control deviation and the control variable of the water valve can be calculated.
	Water meter impulse unit	Settings of the water meter impulse unit
	Water meter impulse rate	Input of the water meter impulse rate

Commissioning procedure

Section	Parameter	Description
Motor management switched on in this controller	-	Motor management can be activated in the aicore fusion. Functions for controlling fans are available.
Fans	Fan drive	Fan drive type selection. A selection is made between EC fans controlled via Modbus and analogue controlled power units, e.g. with AC fans. <i>This selection is available only for the aicore air ec/aicore fusion controller variant.</i>
	Control value limitation	An optional limitation of the control value output can be configured here. This allows partial load operation of fans that are connected via an analogue controlled power unit. In the process, the calculated control value in the interval [0..100] % is rescaled into the output interval [0...Control value limitation] %. <i>This selection is available only for the aicore air ec/aicore fusion controller variant and analogue fan drive.</i>
	Number of fans	Setting the number of fans on the heat exchanger. <i>This selection is available only for EC fans.</i>
	Number of fan types	Setting the number of fan rows on the heat exchanger. Query only occurs if the number of fans is greater than one.
	Fan parametrization	Selection of the parametrization of the fans with or without fan ID. <i>This selection is available only for EC fans.</i>
	Maximum speed	Setting the maximum fan speed (working point). This selection is available only for EC fans.
Fan scan	-	Display of the result of the fan search. If the fan parametrization without fan ID has been selected, the maximum speed per fan can be adjusted at this point. <i>This overview is available only for EC fans.</i>
Heat exchanger	Number of control cycles	Setting the number of control cycles within a heat exchanger. Selection is made between 1 or 2 control cycles. The service menu can be used for extended parametrization of up to 5 control cycles.
	Operating mode	Setting the operating mode of the regulation

Commissioning procedure

If you would like to carry out start-up again, you can reset the controller to its delivery state in the service menu.

3.1.2 Detailed start-up procedure with EC fans

The system date and time are set first.

In the event of a power cut, the system clock will remain set for 4 – 7 days depending on the external temperature. The system time may need to be set again (e.g. after the Güntner unit is delivered ex works until it is actually commissioned). Press [Modify] or [➤] to continue.

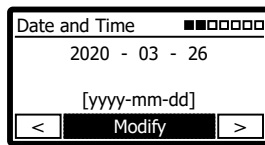

The system of units shown on the display is then set.

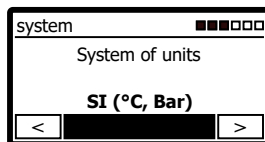

Next, decide whether to turn on pad wetting.

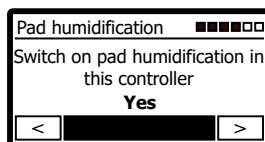

Now the altitude above sea level is required. It is necessary to input this in order to calculate the volume of water.

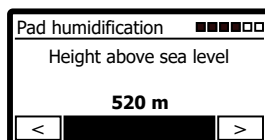

The maximum flow must then be set so that the control deviation and the control variable of the water valve can be calculated.

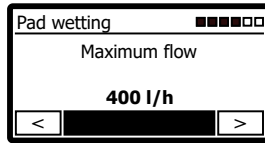

The **impulse unit** usually doesn't have to be changed. The setting can be found in the water meter data sheet.

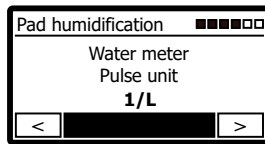

The same applies to the **pulse rate**.

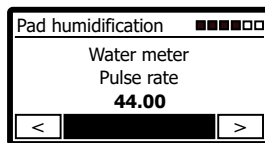

3.1.3 Detailed start-up procedure with motor management

If the aicore fusion is not only used for wetting the pad, then the motor management settings for the fans follow.

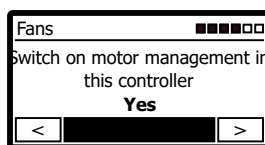

Now the fan drive is selected. Depending on the motor type, you can choose between Modbus EC or analogue.

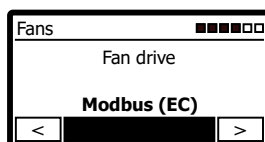

You can now set the number of fans installed on the heat exchanger.

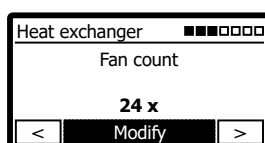

Depending on the unit type (8/16/24), a maximum of 24 fans can be connected to a controller. Set the number of connected fans accordingly.

NOTICE

The aicore fusion expects the fans to be in ascending order from fan connection 1 to the set number of fans.

If the number of fans is larger than 1, you will now be asked how many fan rows the heat exchanger has. This layout information is important for the controller if for example fan groups are formed or pairs of fans are controlled. Select “1” for a unit with one row or “2” for a unit with two rows.

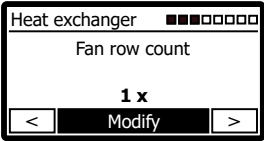

A check will then be carried out to ensure that the communication with these fans is working correctly. Press [>] to continue.

In the steps that follow, the fans’ operating point will be defined. As a result, the maximum heat exchanger power and the maximum sound emissions are defined. By default, this is defined via a so-called **Fan ID**. The fan ID determines the maximum speed for a specific fan type (FT number). Generally speaking, this can be found along with the maximum speed and the FT number in the attached diagram or on a separate notice on the heat exchanger. **Configuration with the help of a fan ID is the standard procedure** and ensures that the heat exchanger is set to the correct working point.

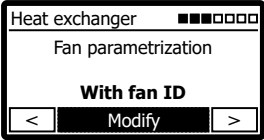

Alternatively, configuration can be carried out **without a fan ID**. In this case, only the maximum speed needs to be set. If desired, this can be set for each fan too.

In the next step, the fan ID is entered:

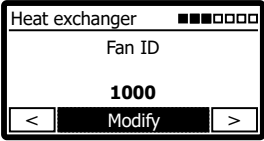

NOTICE

When changing a numerical value, you can **press and hold the rotary selection knob (2s)** to change the cursor and then select which digit you wish to change.

In the next step, you need to enter the maximum speed. If you are commissioning the unit with a fan ID, this step functions as a safety check.

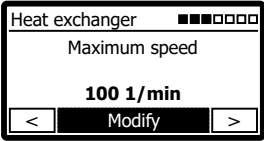

The result of the check is then shown. If the set number of fans matches the number of fans found, the connection status, the fan number (FT number and version), the set operating point speed and the maximum possible speed will be shown for each fan.

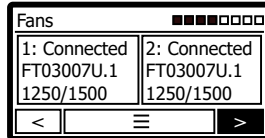

In order to scroll through the list of fans, select [Menu] and scroll through the list with the help of the rotary knob. If necessary, you can view all details for a fan.

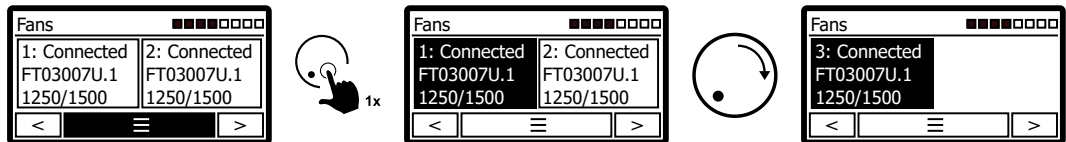

To exit the view, press the “Back” button.

Otherwise, press [>] to continue with the start-up.

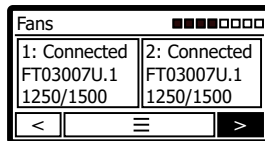

If there is a problem during the search or an incorrect fan was installed, this will be indicated by [!].

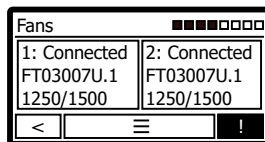

Select [!] to see the result of the fan search.

You can go a step back and scroll through the list to find out which fans are connected incorrectly.

Now disconnect the controller and the fans, check the cabling, the bus connection terminals and possibly the fan itself and then start the start-up process again. The parameters you have entered so far will be retained.

Now select [>] in the search result to continue with the start-up.

You will then be asked how many control cycles are installed on the heat exchanger. Press [Modify] or [>] to continue.

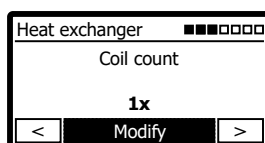

The next step involves setting the operating mode for the controller.

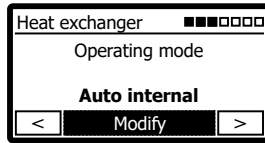

The following options can be selected:

Operating mode	Way of working
Auto internal	The controller records the actual temperature or pressure and adjusts it automatically to a setpoint which can be configured via the menu.
Auto external analogue	The controller records the actual temperature or pressure and adjusts it automatically to a setpoint which is set externally in an analogue fashion.
Auto external bus	The controller records the actual temperature or pressure and adjusts it automatically to a setpoint which is set via the fieldbus interface.
Slave external analogue	The controller obtains the control value for the fans via an analogue signal.
Slave external bus	The controller obtains the control value for the fans via the fieldbus interface.

In the next step, configure the control cycles for the heat exchanger.

First of all, configure the heat exchanger type.

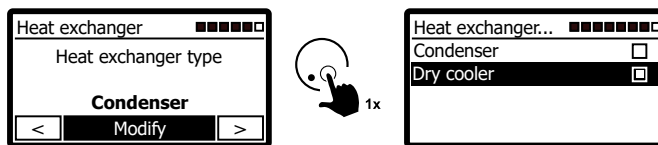

If you have set condenser as the heat exchanger type, you can also select the refrigerant. The controller can then calculate the condensing temperature based on the measured condensing pressure. If the refrigerant is not listed, please use [Bar].

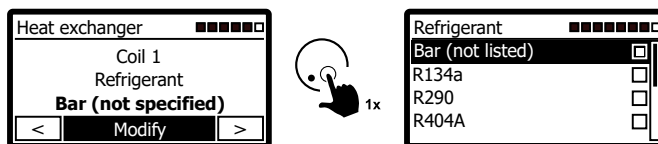

If you are using a condenser with an unknown refrigerant, configure the type of pressure sensor if necessary.

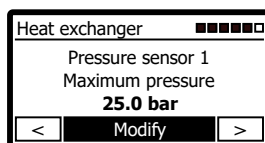

You have now entered all the necessary information for operating the controller and the start-up process is complete. After start-up, the menu language once again switches to English. This can be set under “Language” in the menu.

🏠	Auto internal	12:32 PM
<	Coil 1 of 1	>
Setpoint 1	30.0°C	
Outlet temperature	27.1°C	
Air volume	0 %	

All functions, fan settings, IO configurations and sensors can also be set via the main or service menu.

To get to the main menu, press the rotary selection knob in the home menu.

To get to the service menu, select “Service” in the main menu.

If you would like to carry out start-up again, you can reset the controller to its delivery state in the service menu.

4 Structure of the aicore fusion

4.1 Installing the aicore fusion

4.1.1 Installing the controller, ventilation

If the unit has been taken from a very cool storage location, leave it at room temperature for 1- 2 hours before installation with the lid open to allow any residual moisture to disperse and hence avoid malfunctions during start-up. The unit may only be commissioned when it is absolutely dry. The sachet of silica gel (desiccant sachet) must be removed.

Once the unit has been commissioned for the first time, the power supply and the internal control voltage must no longer be switched off for a long period. If this should nevertheless be necessary for operational reasons, suitable moisture protection must be provided.

There are 4 drill holes in the housing for mounting. The equipment may only be fixed at these points, any manipulation of the housing (e.g. drilling new mounting holes) is prohibited.

The cable entry must always be underneath; installation with cable entries at the side or even on top is not permitted!

If moisture problems occur in the housing owing to considerable external heating and cooling, the moisture must be dispersed by means of an air equalisation (cable gland with equalisation opening).

Keep an eye on good accessibility! The unit must be easily accessible for any maintenance work.

Please note:

- If the unit is installed in a switch cabinet, **proper attention must be paid to the temperature** inside the cabinet (see "[Electrical properties](#)").
- A hood is required if the equipment is installed in the open air.
- Install the aicore fusion out of direct sunlight and choose a location with the best possible protection against the elements.

4.2 Connecting the aicore fusion

The connecting terminals for the potential-free signal outputs, the control inputs (controller release etc.) can be found on the top terminal and on the terminal below.

The mains connection is on the bottom terminal X2.

The power supply (single-phase 230 V or 3-phase 400 V) and the connection of the bus lines to the EC fans are located in a separate small switch cabinet.

4.2.1 Position of the connections on the aicore fusion

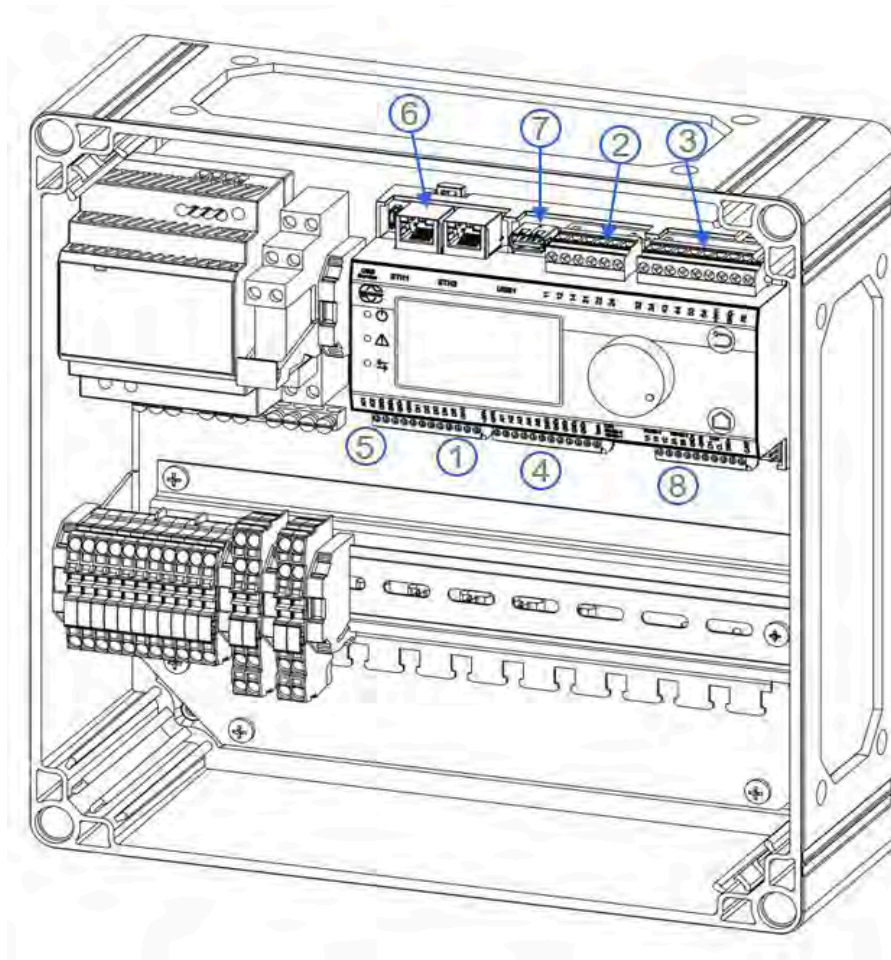

Position of the connections on the aicore fusion

Type.	Number	Description
Digital Input (DI1...DI4)	1	Digital inputs +24V, GND as Reference potential
Digital output (DO1, DO2)	2	Digital outputs, potential-free NC-COM-NO
Digital output (DO3...DO5)	3	Digital outputs, potential-free NO-COM
Analogue input (AI1...AI5)	4	Analogue inputs, depending on configuration
Analogue output (AO1, AO2)	5	Analogue outputs, depending on the configuration
Ethernet connection	6	Modbus TCP
USB connection	7	USB2.0, software update
RS485	8	Modbus RTU

4.2.2 Controller mains connection

The mains connection for the controller is on terminal X2:

- 1** = **L1** Phase conductor
- 2** = **N** Neutral conductor
- PE** = Earth conductor

The connector terminals are designed for a maximum wire cross-section of 2.5 mm².

The supply line must- fused by means of automatic circuit breakers with characteristic "C 6".

NOTICE

The heat exchanger fans may not be switched on or off by switching the mains on or off, but only via the switch.

5 Technical data

5.1 Dimensional drawing of the aicore fusion

The dimensions of the housing and fixings are shown below. All dimensions are given in millimetres.

Fixing drill holes max. \varnothing 7.5 mm.

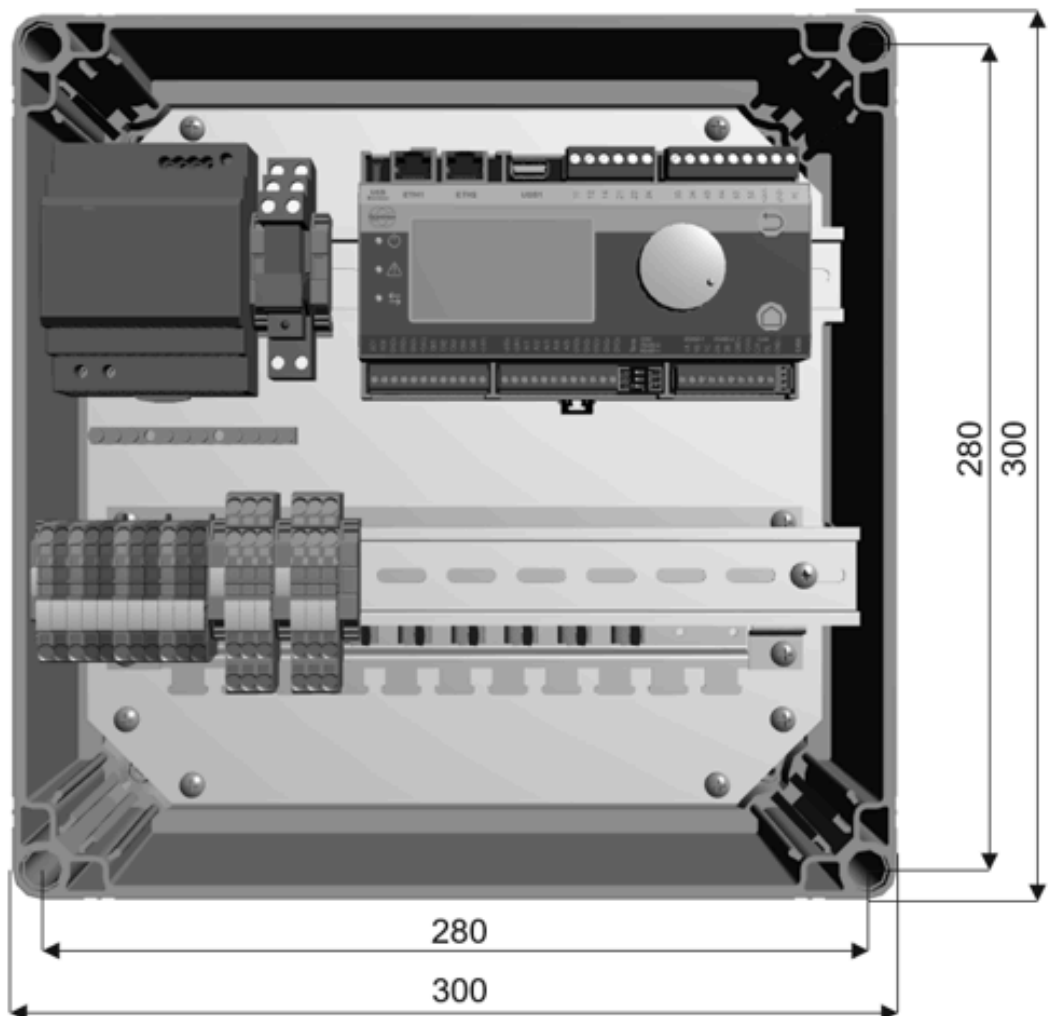

Dimensional drawing of the aicore fusion housing

6 Electrical properties

Description	Min	Type.	Max	Unit
Power supply				
Supply voltage	20	24	28	V
Current consumption (24 VDC) ^{*1)}		200	400	mA
Power consumption ^{*1)}		4.8	9.6	W
Digital inputs				
Potential separation	No			
High level (digital mode) ^{*2)}	16	24	28	V
Low level (digital mode) ^{*2)}	-1	0	5	V
Frequency (digital mode) ^{*2)}			20	kHz
Input resistor	35			kΩ
Relay outputs				
Potential separation	Yes			
Voltage DC		24	30	V
Voltage AC			250	V
Current resistive load (30 VDC)			1.0	A
Current inductive load (30 VDC)			0.45	A
Current resistive load (250 VAC)			1.5	A
Current inductive load (250 VAC)			0.6	A
Switch cycles, mechanical	1*10 ⁵			switch cycles
Switch cycles, electrical	1*10 ⁵			switch cycles

^{*1)} The maximum current consumption includes supplying 2 connected pressure transmitters and 1 connected temperature sensor.

^{*2)} Digital inputs can be operated in analogue or digital mode. The switching levels in analogue mode are configured via software parameters.

Description	Min	Type.	Max	Unit
Analogue input general				
Potential separation	No			
Dielectric strength	-5		30	V
Resolution			12	Bit
Analogue input voltage mode 0..10V				
Measuring range	0		12	V
Error		0.25	0.5	% ^{*3)}
Input resistor	100			kΩ
Analogue input current mode 0..25mA				
Measuring range	0		25	mA
Error		0.25	0.5	% ^{*3)}
Input resistor in the measuring range (without protective circuit)		110	150	Ω
Analogue input PT1000 mode				
Measurement range (resistance)	800		1500	Ω
Error (resistance)		1.5	2.0	Ω
Measuring range (temperature)	-50		130	°C
Error (temperature)		0.4	0.6	K
Measured current		1	1.4	mA
Voltage output 0..10V				
Potential separation	No			
Voltage range	0		10	V
Load resistance		>=5		kΩ
Resolution			12	Bit
Error ($I_{out} \leq 1\text{mA}$)			1	% ^{*4)}
Short circuit protection	Yes			
Short circuit current (I_{out_max})			5	mA
Ethernet interface 1 / 2				
Dielectric strength			2	kV
Transmission rate	10		100	MBit
Autonegotiation	Yes			
Auto MDI-X	Yes			
Galvanic separation	Yes			

*3) error relating to measuring range end value

*4) error relating to range end value

Description	Min	Type.	Max	Unit
USB service interface				
OTG capability	Yes			
Voltage supply U_{out} (host mode)	4.5	5		V
Voltage supply I_{out} (host mode)			500	mA
Transmission rate	1.5		480	Mbit/s
USB1 interface				
OTG capability	No			
Voltage supply U_{out} (host mode)	4.5	5		V
Voltage supply I_{out} (host mode)			500	mA
Transmission rate	1.5		480	Mbit/s
CXP interface				
Plug and play recognition of expansion module	Yes			

Electrical properties

- All measurement and signalling lines must be connected via shielded cables.
- The shielding of measurement, signal and bus lines must be earthed at one end only.
- Suitable shielding and routing measures must be taken to ensure that mains cables and motor cables do not cause any interference in signal and control lines.
- Recommended RS 485 cables: Belden9841, Lapp Unitronic LD 2170203 / 2170204 / 2170803, Helukabel 81910
- Recommended Ethernet cables: min. CAT.6, CAT.7 cable structure: S/FTP (overall shield mesh, pair shield foil), F/FTP (overall shield foil, pair shield foil), SF/FTP (overall shield mesh+foil, pair shield foil)
- Temperature in operation: -20°C ~ +65°C
- Temperature for storage and transport: -20°C ~ +70°C, dry
- Protection class: IP 20

7 Annex

7.1 Default I/O configuration

	DI1	DI2	DI3	DI4	DI5
Function	Release (all control cycles)	(Night) setback*	Enable wetting system	External drain	Water meter
Wire break-proof input	No	No	No	No	No

Default configuration of digital inputs after commissioning

*: The maximum control value for the setback can be set, e.g. via the "Night setback" menu.

	DO1	DO2	DO3	DO4	DO5
Function	Alarm message (Prio 1)	Warning message (Prio 2)	In operation	Humidification is active	Close drain valve
Wire break-proof output	Yes	Yes	No	No	No

Default configuration of digital outputs after commissioning

	AO1	AO2
AO profile	0-10V	0-10V
Function	Control value/Control value analogue operation***(fan group 1)	Water inlet valve control value

Default configuration of analogue outputs after commissioning

***: "Control value analogue operation" will be output if the fan drive was set to "Analogue" during commissioning.

	AI1	AI2	AI3	AI4	AI5
Operating mode	4-20mA	0-10V	PTC / PT1000	0-10V	PTC / PT1000
Slave external analogue	-	Control value fans (control cycle 1)	-	Control value fans (control cycle 2)**	-

Default configuration of analogue inputs after commissioning for dry coolers and condensers and slave operating modes

	AI1	AI2	AI3	AI4	AI5
Operating mode	4-20mA	0-10V	PTC / PT1000	0-10V	PTC / PT1000
Slave external bus	-	-	-	-	-

Default configuration of analogue inputs after commissioning for dry coolers and condensers and slave operating modes

**: If two control cycles are set, otherwise free.

Operating mode	4-20mA	0-10V	PTC / PT1000	0-10V	PTC / PT1000
Auto internal & Auto external bus	-	-	Actual value temperature sensor (control cycle 1)	-	Actual value temperature sensor (control cycle 2) **
Auto external analogue	-	Control value specification (control cycle 1)	Actual value temperature sensor (control cycle 1)	Control value specification (control cycle 2) **	Actual value temperature sensor (control cycle 2) **

Default configuration of analogue inputs after commissioning for dry coolers and automatic operating modes

**: If two control cycles are set, otherwise free.

Operating mode	4-20mA	0-10V	PTC / PT1000	0-10V	PTC / PT1000
Auto internal & Auto external bus	Actual value pressure sensor (control cycle 1)	-	Actual value pressure sensor (control cycle 2) **	-	-
Auto external analogue	Actual value pressure sensor (control cycle 1)	Control value specification* (control cycle 1)	Actual value pressure sensor (control cycle 2) **	Control value specification* (control cycle 2) **	Actual value temperature sensor (control cycle 2) **

Default configuration of analogue inputs after commissioning for condensers and automatic operating modes

*: If a refrigerant is selected, a temperature setpoint is specified, otherwise a pressure setpoint.

**: If two control cycles are set, otherwise free.